

Purpose

As with any home owner in Sioux Falls, manufactured home owners or occupants must comply with the ordinances of the City of Sioux Falls. The purpose of this handout is to define what your responsibilities are under these ordinances.

Placement Permits

Whenever a manufactured home is placed on a lot, the manufactured home owner is required to file a placement permit application along with the filing fee of fifty dollars (\$50) to the Building Services Department within five (5) days of placement (Section 24-8). Applications may be obtained from the manufactured home park owner/manager, who will fill out the "Property Information" section of the application. The manufactured home owner must complete the "Owner Information" section, which includes the make, model, and serial number of the manufactured home. Applications can be mailed or delivered in person to the Building Services Department at City Hall, 224 West Ninth Street. Mailing address and contact information are at far right. After the application and fee are received in the Planning and Building Services Office, the electrical, plumbing, fire (if necessary), and zoning inspections will be made. After all final inspec-

tions are made, you will receive a copy of the application and a numbered silver tag will be placed on the front of the manufactured home.

Electrical Requirements

A licensed electrician is required to connect the manufactured home to the power service and call the Electrical Inspector for an inspection. Your power supplier will not give you power until authorized by the Electrical Inspector. The Inspector will need access to the panel inside the manufactured home when making this inspection.

Plumbing Requirements

Persons hooking up sewer and water service connections must be licensed.

Building Permits

Prior to the start of any type of construction, a separate building permit is required to be issued for any structure; i.e., shed, deck, premanufactured addition, vestibule (40 square feet maximum), garage, carport, etc. There are different requirements for each type of project, which will be explained at the time a building permit is issued. Structures that are moved onto the lot (sheds, decks, etc.) also require a building permit prior to the structure being

placed on the lot. Permits are not required for work done inside the manufactured home.

Note: Maximum depth allowed for carports, canopies, and garages in manufactured home parks is 28 feet.

Information Required for a Building Permit

You will need to furnish the dimensions of the structure, construction plans, and the distances between the structure and any structures on an adjacent lot. A certificate of compliance issued by the manufacturer must be provided for all premanufactured additions (cabanas).

Address Numbers

It is required that the manufactured home space or street number be affixed to the front of each manufactured home or displayed in the front of each manufactured home. The minimum size of numbers is required to be 3" x 2".

Building Services

224 West Ninth Street

P.O. Box 7402

Sioux Falls, SD 57104-7402

(605) 367-8254

TTY/Hearing Impaired (605) 367-7039

www.siouxfalls.org

Manufactured Home Park Layouts

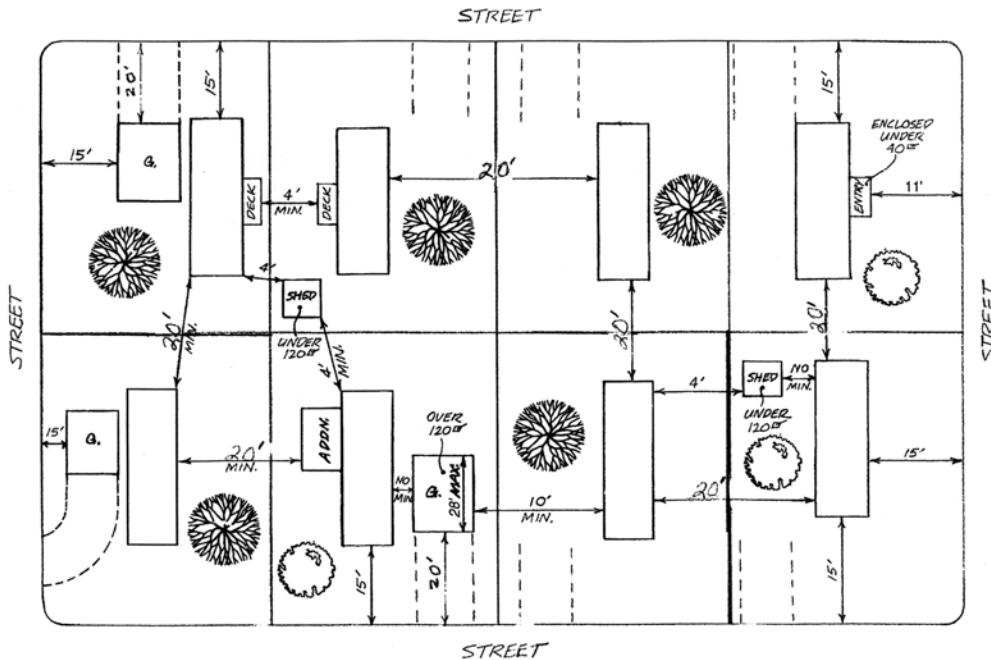

Example shows minimum required setbacks for sheds, garages, decks, vestibules, etc. Distances between mobile homes vary depending on when the park was established. (Park manager is responsible for correct location of the manufactured home on the lot.)

Deck Information

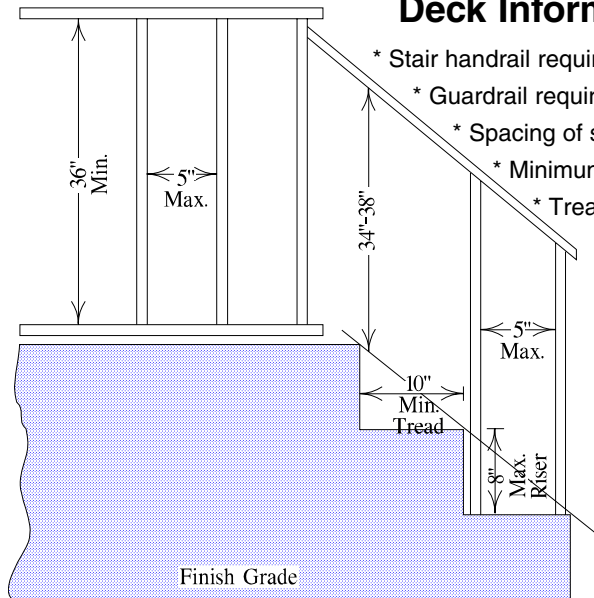

- * Stair handrail required only when there are 4 or more risers.
- * Guardrail required only when platform exceeds 30" height.
- * Spacing of spindels or rails not to exceed 5".
- * Minimum height of guardrail 36".
- * Tread is measured from nose to nose.

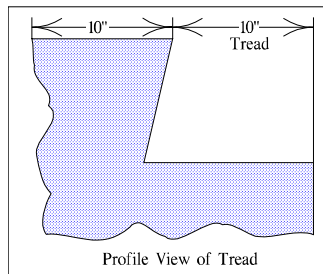

Manufactured Home Owners' Responsibilities

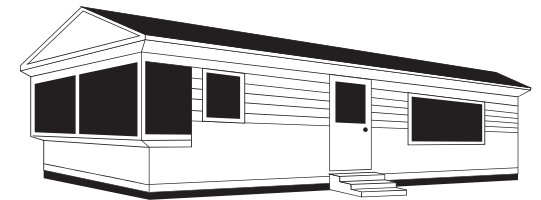

Prepared by
City of Sioux Falls
Planning and Building Services

Revised December 2005

